

ADJUSTABLE FRAME INSTALLATION PROCEDURE

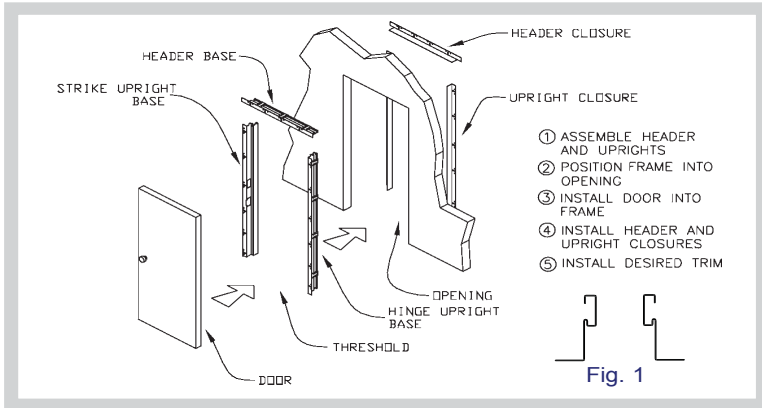

Fig. 1

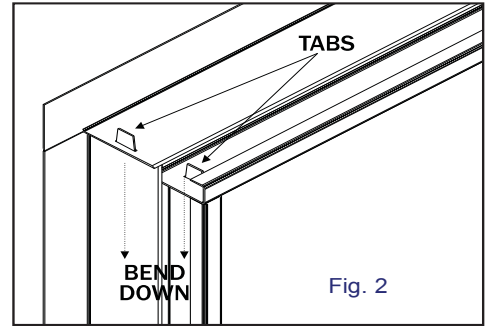

Fig. 2

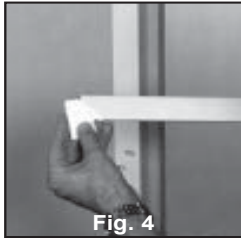

Fig. 4

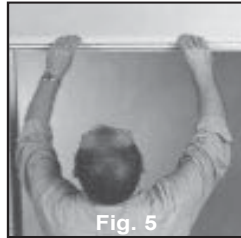

Fig. 5



Fig. 6

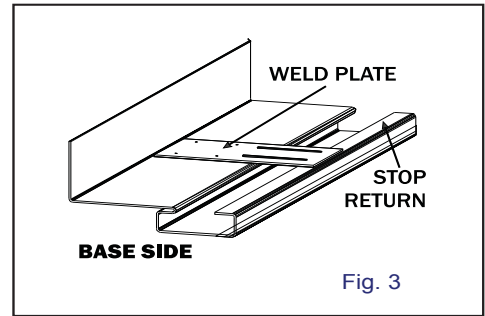

Fig. 3

- 1** Open carton and remove all frame components. Inspect for any damage. If damage is apparent, notify dealer or sales representative immediately to expedite replacement.
- 2** Assemble base side of frame (which consists of hinge jamb, strike jamb, and header) by placing the face or nailing flange face down on a flat surface (Fig. 1). Insert tabs which are located on the ends of the jambs into the slots in the header. Bend tabs outward and down to secure tight fit between the jambs and header (Fig. 2). Stand frame upright and place into rough opening. **Note:** If using threshold, install prior to placement into rough opening.
- 3** Square header and hinge jamb by using a carpenter's square, then secure the corner of the header. Using a level, plumb the hinge jamb and secure (begin at the top). Repeat process for strike jamb.
- 4** Install door and close in frame opening using the door as a template. Adjust frame to door so that clearances between the door and the frame are equal and between 1/16" (2) and 1/8" (3). After adjusting for proper fit, secure with recommended screws.
- 5** Install closure pieces from rear side by guiding closure between plate and stop. Begin at either end of any closure piece. It may be necessary to apply slight pressure to the outside of frame at start point to allow

closure to go between plate and stop. When all closure pieces are installed and clearances set, fasten to wall. **Note:** While installing closure pieces, make sure the closure goes between the stop return and each individual weld plate of the base side of frame (Fig. 3).

- 6** Install weatherstripping or smoke gasketing as required, lockset, and adjustable strike. Adjust strike to remove any movement of door after latching. Add additional fasteners if required.
- 7** To apply WOOD casings, locate "T" mark on face of frame. Place edge of casing parallel to "T". Locate casing nail approximately 1/2" (13) back from top of "T" and centered, then drive. This will allow nailing through the frame through the oval slot (Fig. 10, Fig. 12).
- 8** To apply STEEL, ALUMINUM and S56 STEEL COLONIAL casings, slide corner alignment pieces into header ends so the edges of corner pieces are securely fitted inside the casing channel. Center header casing on frame and snap into place by hooking casing edge under outside of casing lance, then snapping over inside of lance. DO NOT FORCE CASING OVER BOTH SIDES OF LANCE SIMULTANEOUSLY. Hold jamb casing at a slightly outward angle and fit mitered end over corner piece protruding from header casing; push upward

to meet miter of header casing. Make certain that jamb casing is aligned with jamb casing lances (tap header left or right as needed with hammer handle) and hook casing over outside lance. Survey miter joint for secure fit (adjust header casing left or right as needed), then snap casings over inside of lance and complete opposite sides (Fig. 4,5,6,9,12).

TO REMOVE CASING, use a small common screwdriver with a flat edge or a stiff putty knife. Start at the bottom of the upright casing on the **inside** of the frame. Gently insert the edge of the screwdriver between the casing and the leg of the frame. Slowly work the screwdriver up the casing to the first lance. Rotate the screwdriver in a **counter-clockwise** motion; the casing will pop off the inside curl of the lance. Repeat this procedure with remaining lances. After all inside lances have been cleared, gently ease the casing from under the **outside** lance curl and remove.

SPECIAL PRODUCT APPLICATION REQUIREMENTS

PAINT: Primed units should be painted within 30 (thirty) days with an oil-based enamel (recommended) or a high quality water base latex. A flash rust inhibitor must be used with water base latex method. Consult factory.

REDIFLEX RF SPECIFICATIONS

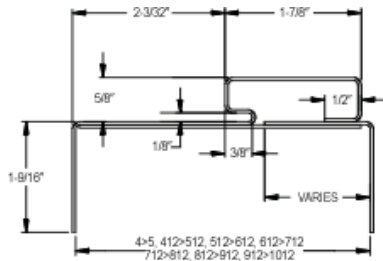

KERF REDIFLEX ADJUSTABLE 18 GAUGE STEEL

Available for 1-3/4" doors only

Prefinished Bright White

Base side: 18 gauge

Closure side: 22 gauge

2-1/4" Lip Strike prep

Galvanized (A-40) steel per ASTM-653

4" to 10-1/2" wall sizes (1" adjustment)

5/8" stop height

Demountable without damage to the finished wall, door, or frame

Prepped with anchoring holes with slots for wood casing

Embossed 90 minute neutral and positive pressure fire label; wood or steel stud.

ROUGH OPENING

WIDTH ADD 1" TO NOMINAL DOOR SIZE

HEIGHT ADD 1-3/4" TO NOMINAL DOOR SIZE

EXAMPLE: 3/0X6/8 R.O. - 37"X81-3/4"

DEDUCT FOR OUTSWING 3/4"

DEDUCT FOR HANDICAP SILL 3/4"

All Rediflex Frames are embossed between top and second hinge with a Non-Removable 90 min. Warnock Hersey Label to certify Fire Rating

ADA COMPLIANT THRESHOLD FOR RF FRAMES

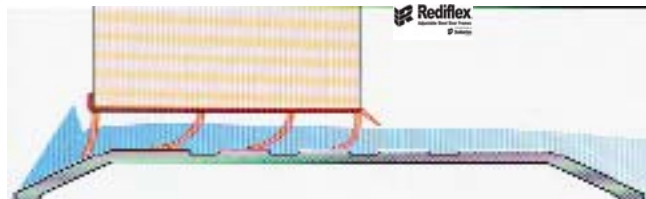

4" X 4" NON-TEMPLATE HINGE

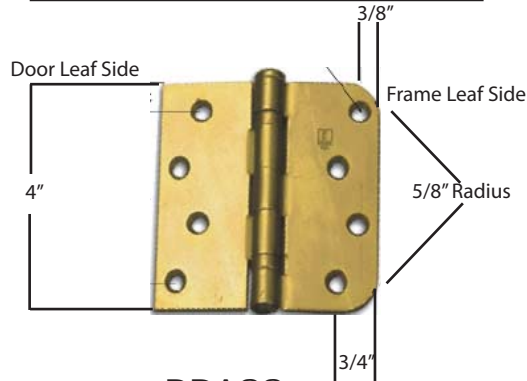

DOOR LEAF SIDE

FRAME LEAF SIDE

BWI is YOUR AUTHORIZED WARNOCK-HERSEY DOOR SHOP



STANDARD SPECIFICATIONS & OPTIONS FOR DOORS AND UNITS IN SECTION "E"

WOOD & REDIFLEX FRAME W/ INSWING ALUMINUM SILL							
SPECS ARE TOP OF DOOR TO TOP OF HINGE & CENTER OF BORE							
DR HGT	FINISHED DR HGT	1ST	2ND	3RD	4TH	BORE	DEADBOLT BORE
6/8	79-1/8"	6-7/16"	37-5/8"	68-13/16"		43-11/16"	38-3/16"
7/0	83-1/8"	6-7/16"	39-5/8"	72-13/16"		47-3/4"	42-1/4"
8/0	95-1/8"	6-7/16"	32-9/16"	58-11/16"	84-13/16"	59-11/16"	54-3/16"
RATED STEEL UNITS CAN NOT BE CUT DOWN.							
RF WOOD & MLD UNITS CAN NOT BE CUT UNDER 77" DOOR HEIGHT							

OPTIONS			
HINGE OPTIONS		SINGLE	TWINS
4" SELF CLOSING HINGES : BRASS, POLISHED CHROME, DULL CHROME, SATIN NICKEL, ANTIQUE BRASS, AND OIL RUBBED BRONZE	ADD	INCLUDED	INCLUDED
SILL OPTIONS			
OUTSWING SILL	ADD	36.20	36.20
HANDICAP SILL	ADD	22.00	22.00
ADJUSTABLE SILL UNIT	ADD	18.60	N/S
CERAMIC TILE ADA SILL	ADD	22.00	N/S

HANDING CHART FOR DOORS

