

# DOOR CLOSER

## MODEL 73 INSTALLATION INSTRUCTIONS

### CHART TO DETERMINE HAND OF DOOR

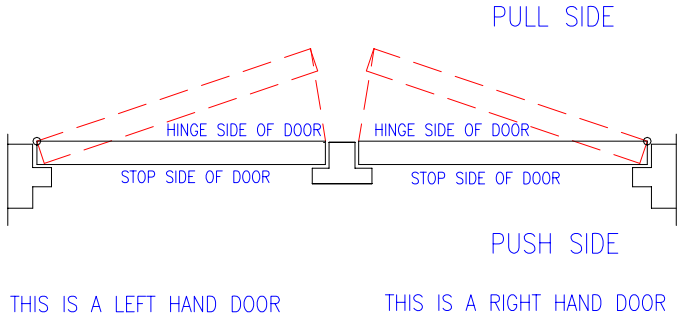

### FINAL ADJUSTMENT AND REGULATING PROCEDURES

#### REGULATING DOOR SPEED AND LATCHING SPEED

TURN SPEED REGULATING VALVE COUNTER-CLOCKWISE TO SLOW DOWN -OR- COUNTER-CLOCKWISE TO SPEED UP DOOR MOVEMENT

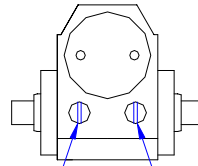

#### ADJUSTING FOOT FOR CLOSING POWER

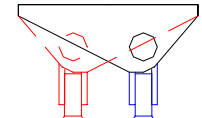

LESS POWER MORE POWER

HINGE EDGE OF DOOR

### STANDARD INSTALLATION: PULL SIDE RIGHT INSTALLATION

RIGHT HAND DOOR ILLUSTRATED  
SAME DIMENSIONS APPLY TO LEFT HAND DOOR  
MEASURED FROM HINGE CL

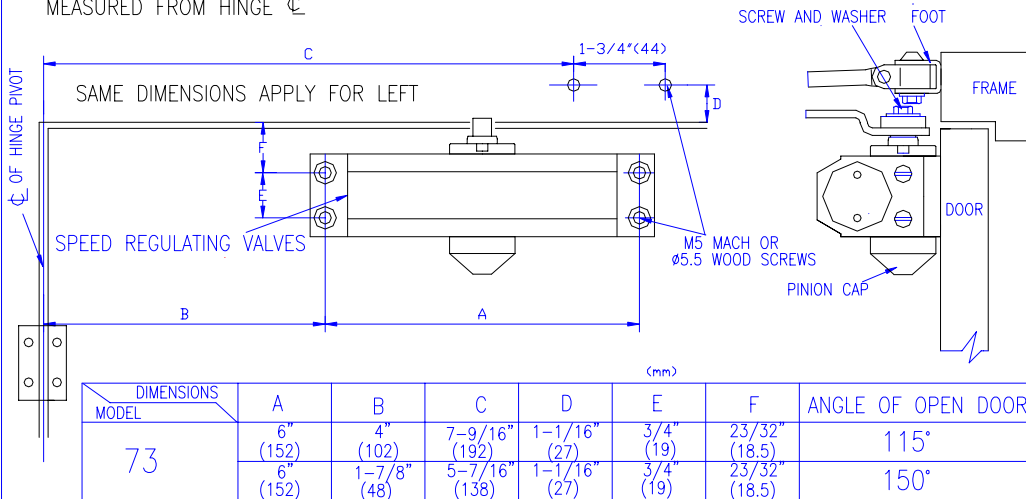

#### INSTALLATION INSTRUCTIONS

- 1.SELECT DEGREE OF DOOR. USE DIMENSIONS SHOWN IN CHART AND ILLUSTRATION ABOVE TO MARK LOCATION OF ATTACHING SCREWS ON DOOR AND FRAME PREPARE HOLES
- 2.ASSEMBLE MAIN ARM TO CLOSER.
- 3.ATTACH CLOSER TO DOOR WITH SPEED REGULATING VALVES TOWARD HINGE.
- 4.ATTACH THE FOOT OF THE FOREARM TO FRAME.
- 5.ADJUST LENGTH OF FOREARM TO POSITION FOREARM AT RIGHT ANGLE TO FRAME WHEN CONNECTED TO MAIN ARM AT ELBOW USE WASHER AND SCREW PROVIDED TO SECURE PIVOT CONNECTION.TIGHTEN LOCKNUT ON FOREARM.
- 6.SNAP PINION CAP OVER SPINDLE AT BOTTOM OF CLOSER.

1

#### POSITION OF ARMS AND INDEX SETTINGS

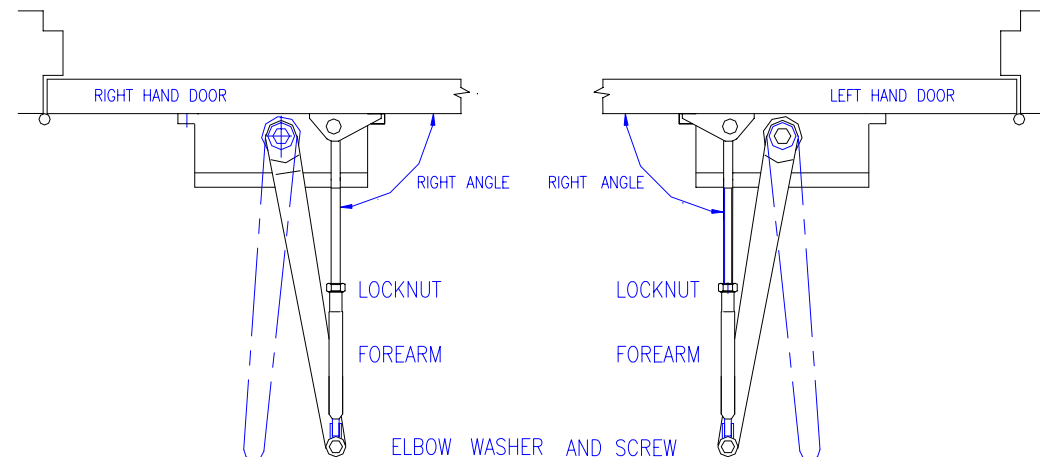

POSITION OF MAIN ARM WHEN ASSEMBLING TO SPINDLE

POSITION OF MAIN ARM WHEN ASSEMBLING TO SPINDLE

#### CLOSING SPEED CONTROL

CAUTION  
DO NOT BACK VALVES OUT OF CLOSER OR A LEAK WILL RESULT

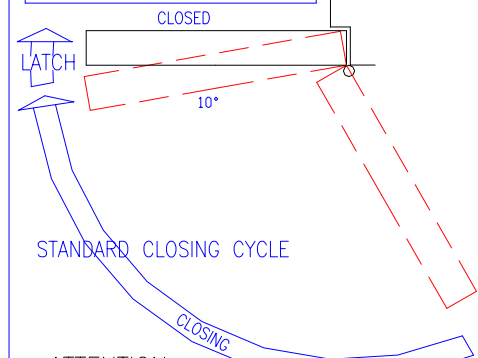

ATTENTION:  
ADJUST CLOSING SPEED TIME TO BETWEEN 4 TO 6 SECONDS FROM 90° USE OF THE DOOR BY HANDICAPPED, ELDERLY OR SMALL CHILD REQUIRE LONGER CLOSING

## OTHER INSTALLATION: PUSH SIDE RIGHT INSTALLATION

LEFT HAND DOOR ILLUSTRATED  
SAME DIMENSIONS APPLY TO RIGHT HAND DOOR  
MEASURED FROM HINGE  $\phi$

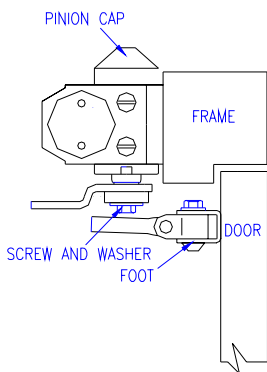
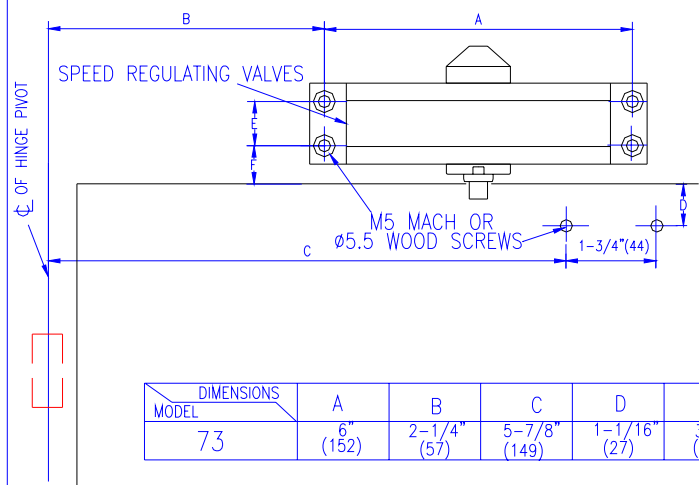

### INSTALLATION INSTRUCTIONS

- 1.SELECT DEGREE OF DOOR. USE DIMENSIONS SHOWN IN CHART AND ILLUSTRATION ABOVE TO MARK LOCATION OF ATTACHING SCREWS ON DOOR AND FRAME PREPARE HOLES
- 2.ASSEMBLE MAIN ARM TO CLOSER.
- 3.ATTACH CLOSER TO FRAME WITH SPEED REGULATING VALVES TOWARD HINGE.
- 4.ATTACH THE FOOT OF THE FOREARM TO DOOR.
- 5.ADJUST LENGTH OF FOREARM TO POSITION FOREARM AT RIGHT ANGLE TO FRAME WHEN CONNECTED TO MAIN ARM AT ELBOW USE WASHER AND SCREW PROVIDED TO SECURE PIVOT CONNECTION.TIGHTEN LOCKNUT FOREARM.
- 6.SNAP PINION CAP OVER SPINDLE AT BOTTOM OF CLOSER

DIMENSIONS		(mm)						ANGLE OF OPEN DOOR
MODEL		A	B	C	D	E	F	
73		6" (152)	2-1/4" (57)	5-7/8" (149)	1-1/16" (27)	3/4" (19)	23/32" (18.5)	180°

2

## OTHER INSTALLATION: PUSH SIDE PARALLEL INSTALLATION

RIGHT HAND DOOR ILLUSTRATED  
SAME DIMENSIONS APPLY TO LEFT HAND DOOR  
MEASURED FROM HINGE  $\phi$

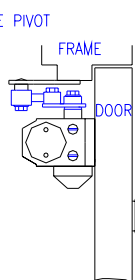
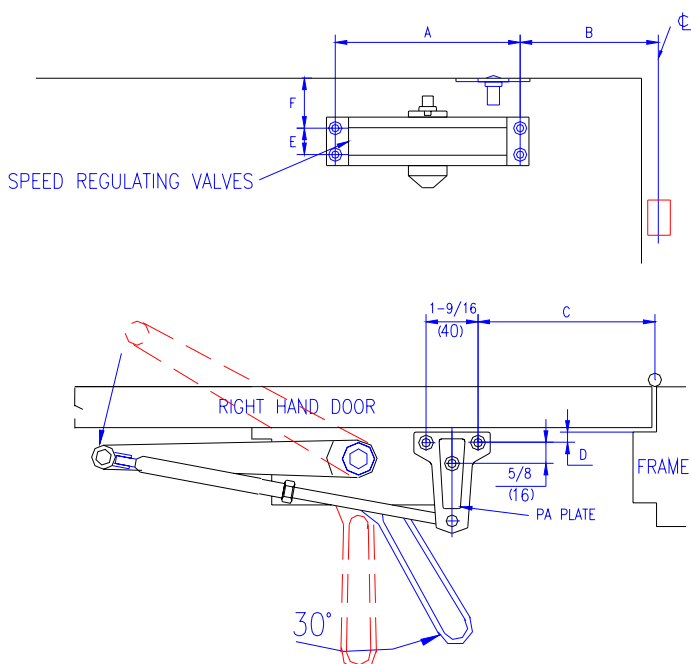

### INSTALLATION INSTRUCTIONS

- 1.SELECT DEGREE OF DOOR. USE DIMENSIONS SHOWN IN CHART AND ILLUSTRATION ABOVE TO MARK LOCATION OF ATTACHING SCREWS ON DOOR AND FRAME PREPARE HOLES
- 2.ATTACH CLOSER TO DOOR WITH SPEED REGULATING VALVES BACK TO HINGE.
- 3.ATTACH MAIN ARM AS FOLLOW:  
(A) PLACE OPEN END WRENCH ON BOTTOM SHAFT & TURN TOWARD HINGE ABOUT 30°.  
(B) PLACE MAIN ARM ON TOP SHAFT, INSERT ARM SCREW INTO TOP OF SHAFT AND TIGHTEN.
4. ATTACH PA PLATE TO TOP FRAME AS SHOWN.
- 5.REMOVE FOOT FROM FOREARM AND DISCARD.
- 6.FASTEN FOREARM TO PA PLATE.
- 7.ADJUST LENGTH OF FOREARM TO POSITION MAIN ARM AT PARALLEL TO FRAME WHEN CONNECTED TO MAIN ARM AT ELBOW USE WASHER AND SCREW PROVIDED TO SECURE PIVOT CONNECTION.TIGHTEN LOCKNUT
- 8.SNAP PINION CAP OVER SPINDLE AT BOTTOM.

DIMENSIONS		(mm)						ANGLE OF OPEN DOOR
MODEL		A	B	C	D	E	F	
73		6" (152)	3-9/16" (90)	4-5/8" (117)	5/16" (8)	3/4" (19)	2-1/2" (63.5)	180°

3

APPLICABLE DOOR: WEIGHT 40-65 Kg