

316 Series Installation Instructions

Multi size 1 thru 6 Non hold open door closers

CAUTION

An incorrectly installed or improperly adjusted door closer can cause property damage or personal injury. These instructions should be followed to avoid the possibility of misapplication or misadjustment

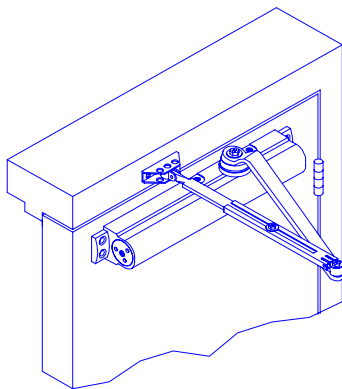

Left hand door-LH
Right hand reverse-RHR

Regular Arm Installation
closer mounts on hinge (pull) side of door
See page 3.
closer cover not shown

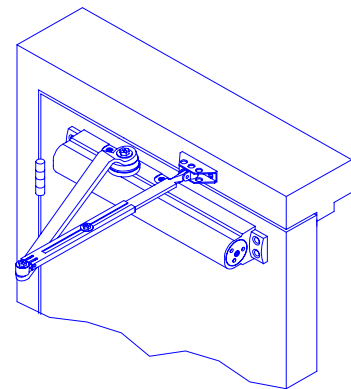

Right hand door-RH
Left hand reverse-LHR

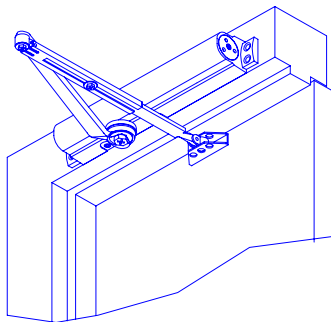

Left hand door-LH
Right hand reverse-RHR

Top Jamb Installation
closer mounts on frame face on
opposite hinge (push) side of door
See page 4.
closer cover not shown

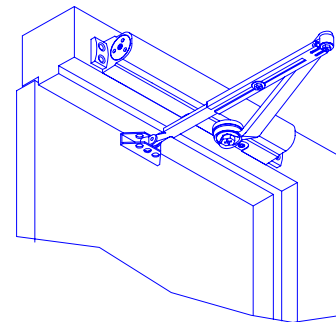

Right hand door-RH
Left hand reverse-LHR

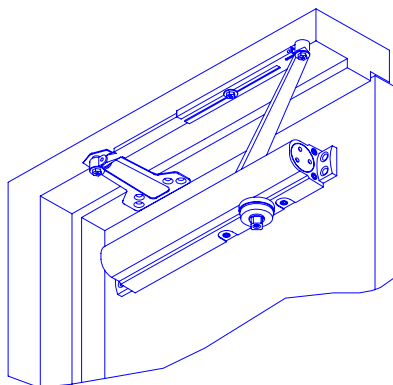

Left hand door-LH
Right hand reverse-RHR

parallel Arm Installation
closer mounts on opposite to
hinge (push) side of door
See page 5.
closer cover not shown

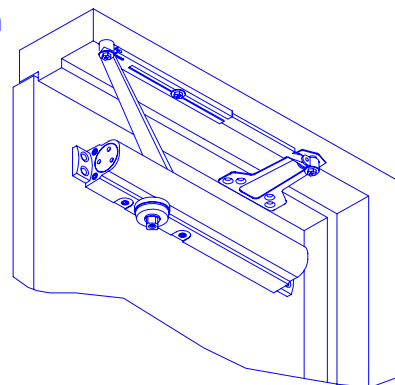

Right hand door-RH
Left hand reverse-LHR

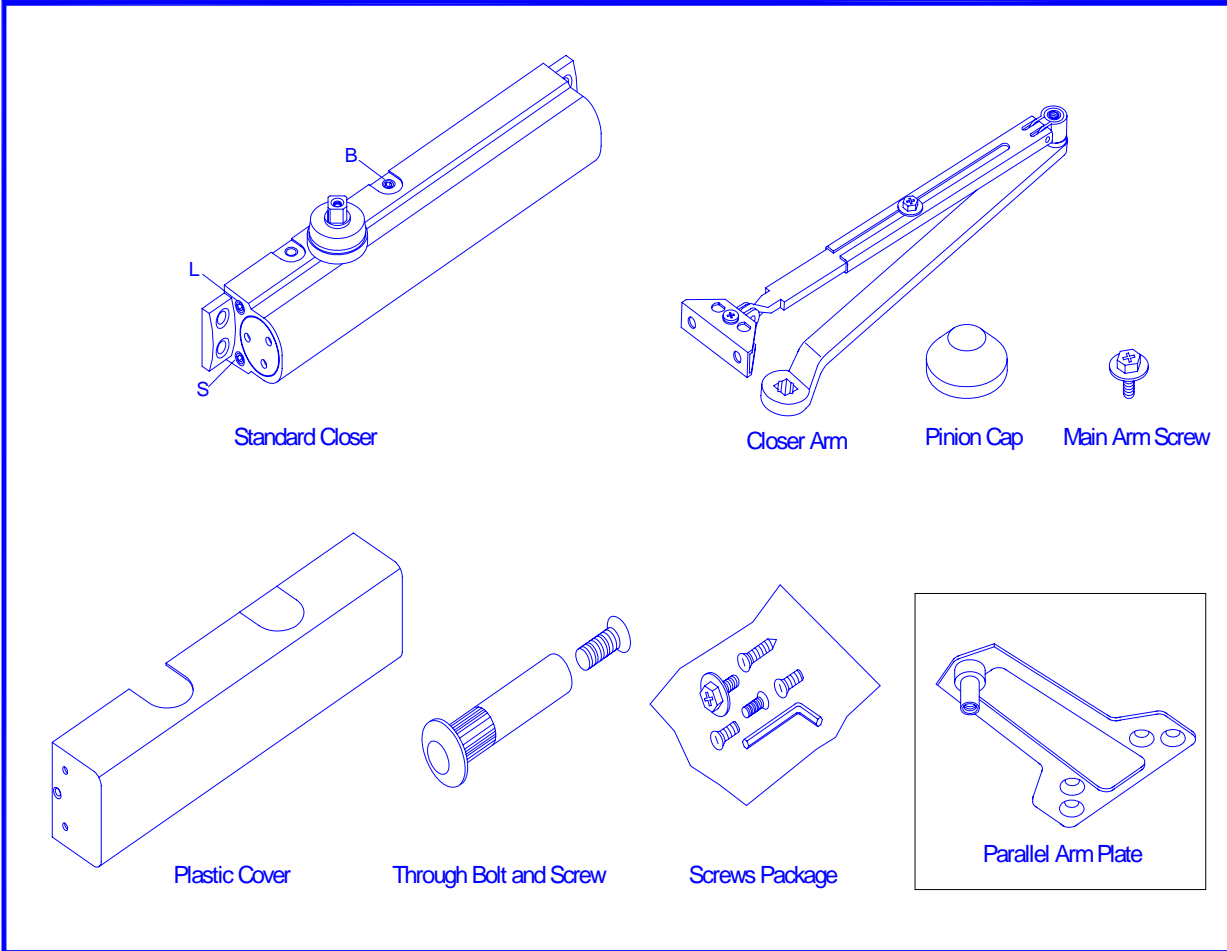

- It is recommended that the door be hung on ball bearing type hinges so door swings freely.
- A separate door stop (supplied by others) is recommended to prevent damage to the door closer, closer arm, or to the door, frame or adjacent walls.
- Door and frame must be properly reinforced or through bolts used to prevent the mounting screws from pulling out.

Preparation for Fasteners		
Fasteners	Door or Frame	Drill-Sizes
Self Drilling/Tapping Machine Screw	Hollow Metal or Aluminum	No drill required
	Wood (see note)	3/16" pilot hole
1/4"-20 Machine Screw	Hollow Metal	Drill #7(0.201" dia.) & Tap 1/4"-20
1/4"-20 Machine Screw used with Through Bolt	Hollow Metal or Aluminum	9/32" drill closer side & 3/8" drill opposite side
	Wood	
Wood Screw	Wood	3/16" pilot hole

NOTE: Wood doors/frames must have a pilot hole drilled when using Self Drilling/Tapping screws.

Installation Instructions

Regular Arm Template

Dot not scale drawing
Right hand door shown
Dimensions are in inches

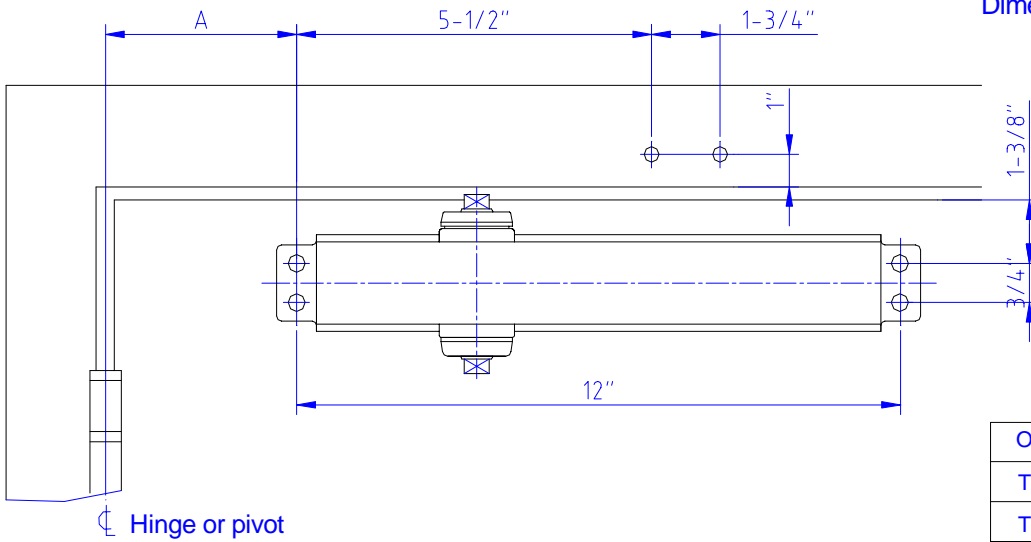

Opening	Dimension "A"
TO 100°	7-1/2"
TO 130°	6"
TO 180°	4-1/2"

Installation sequence

- Select degree of opening and use dimensions shown to locate 4 holes on door for closer body and 2 holes on frame face for arm shoe. For application that are different from above, a separate template will be required
- Prepare door and frame for fasteners. See "Preparation for Fasteners", Figure 2, Page 2.
- Before installing closer body....set spring power for closer using Power adjustment chart, below right.
- Install closer on door with speed regulating valves toward the hinge.
- Remove forearm screw from adjusting rod and disassemble arm. See Figure 1, Fasten arm shoe (with rod) to frame face.
- Mount main arm onto closer pinion shaft, aligning arm mark "S" with pinion flat. Secure with main arm screw.
- Reassemble arm. Adjust forearm length so that it will be perpendicular (at a 90° angle) to the door face. Secure with forearm screw.
- Adjust closer (see page 6) and install cover.

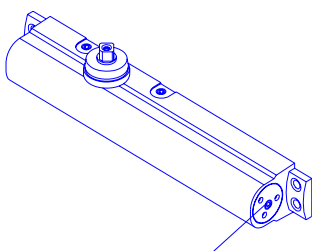
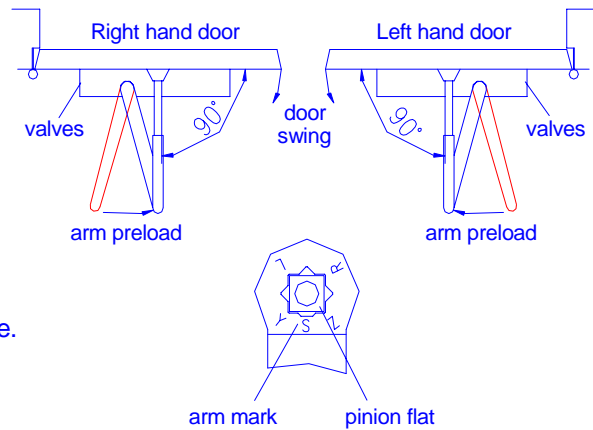

Power Adjustment Nut



To increase power
Turn clockwise 13 turns maximum



To decrease power
Turn counterclockwise

Power Adjustment Chart

door size inches	Full clockwise turns of closer power adjustment nut (from "0" turns)	
	316 series only	
	interior door	exterior door
24"-30"	-7	-5
30"-34"	-3	0
34"-38"	0	4
38"-48"	4	8
48"-54"	8	13
54"-60"	13	

NOTE: Maximum of 20 turns (360°) of power adjustment Nut. Closer is shipped set at 7 turns from the factory

Installation Instructions

Top Jamb Template

Dot not scale drawing
Right hand door shown
Dimensions are in inches

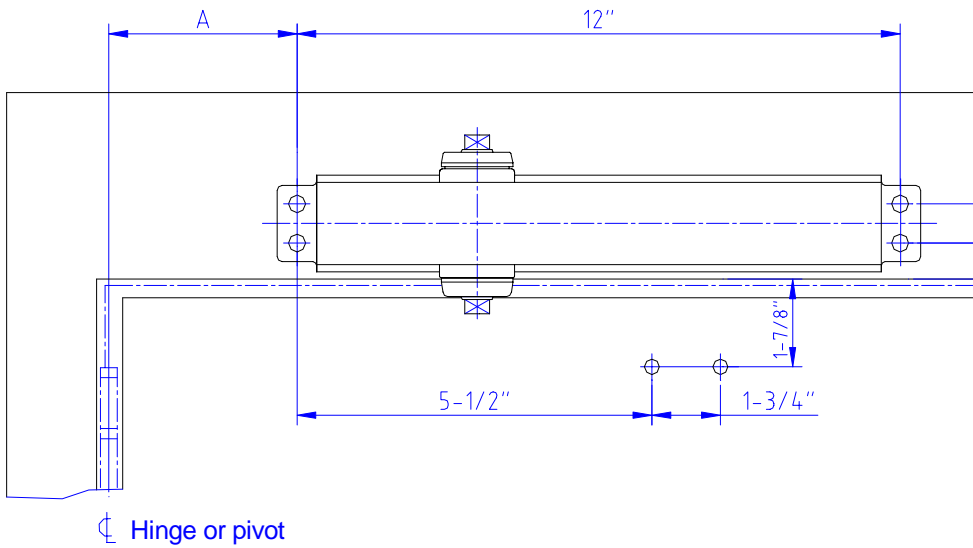

Opening	Dimension "A"
TO 100°	7-1/2"
TO 130°	6"
TO 180°	4-1/2"

Installation sequence

- Select degree of opening and use dimensions shown to locate 4 holes on frame face for closer body and 2 holes on door for arm shoe. For application that are different from above, a separate template will be required
- Prepare door and frame for fasteners. See "Preparation for Fasteners", Figure 2, Page 2.
- Before installing closer body....set spring power for closer using Power adjustment chart, below right.
- Install closer on door with speed regulating valves toward the hinge.
- Remove forearm screw from adjusting rod and disassemble arm. See Figure 1, Fasten arm shoe (with rod) to frame face.
- Mount main arm onto closer pinion shaft, aligning arm mark "S" with pinion flat. Secure with main arm screw.
- Reassemble arm. Adjust forearm length so that it will be perpendicular (at a 90° angle) to the door face. Secure with forearm screw.
- Adjust closer (see page 6) and install cover.

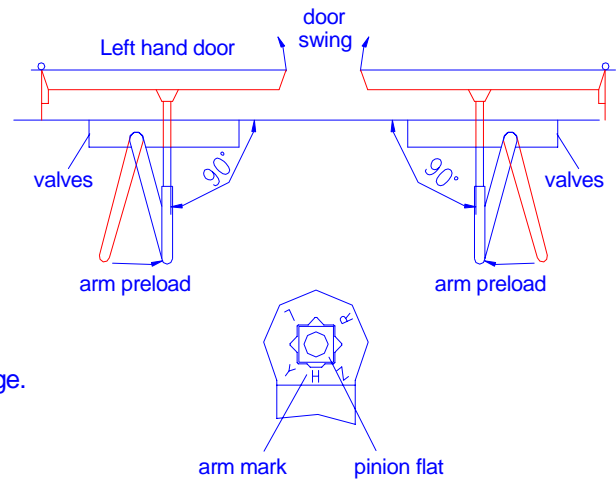

Power Adjustment Chart		
door size inches	Full clockwise turns of closer power adjustment nut (from "0" turns)	
	316 series only	
	interior door	exterior door
24"-30"	-7	-5
30"-34"	-3	0
34"-38"	0	4
38"-48"	4	8
48"-54"	8	13
54"-60"	13	

NOTE: Maximum of 20 turns (360°) of power adjustment Nut. Closer is shipped set at 7 turns from the factory

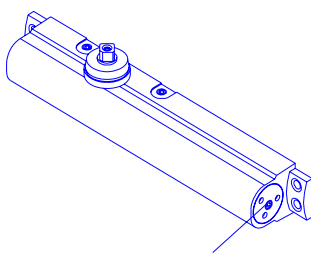

Power Adjustment Nut

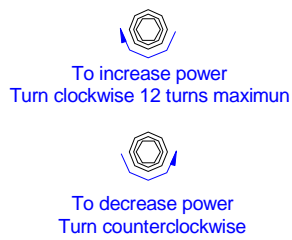

Installation Instructions

Parallel Arm Template

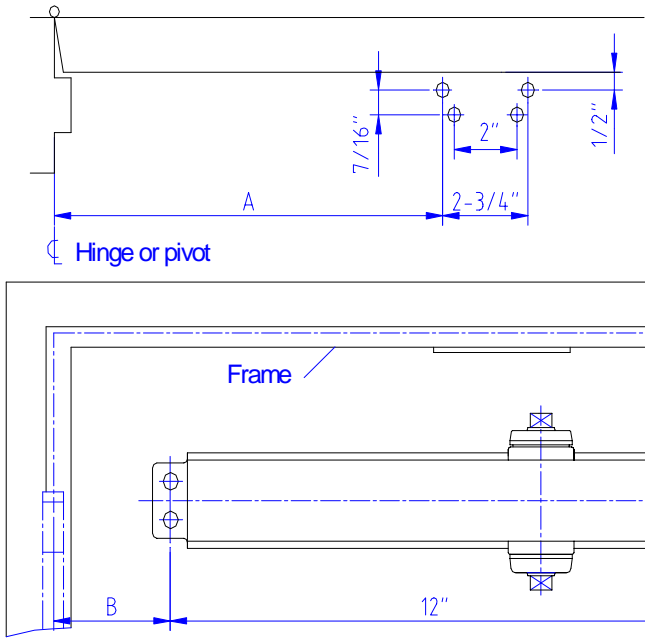

Opening	Dimension "A"	Dimension "B"
TO 120°	9-1/2"	3-3/4"
TO 180°	7"	1-1/4"

Do not scale drawing
Left hand door shown
Dimensions are in inches

Installation sequence

- Select degree of opening and use dimensions shown to locate 4 holes on door for closer body and 4 holes on underside of frame for PA plate. For application that are different from above, a separate template will be required
- Prepare door and frame for fasteners. See "Preparation for Fasteners", Figure 2, Page 2.
- Before installing closer body....set spring power for closer using Power adjustment chart, below.
- Install closer on door with power adjustment nut toward the hinge.
- Mount soffit plate to frame. Remove forearm screw from adjusting rod (See Figure 1) and attach adjusting rod.
- Install main arm on pinion shaft....see main arm installation instructions below.

- Reassemble arm. Preload is accomplished by adjusting forearm length so that it will set arm elbow about 1-1/2" (38mm) from the door face when connected to the main arm. Secure with forearm screw.
- Adjust closer (see page 6) and install cover.

Power Adjustment Chart

door size inches	Full clockwise turns of closer power adjustment nut (from "0" turns)	
	316 series only	
	interior door	exterior door
24"-30"	-4	0
30"-34"	0	5
34"-38"	6	10
38"-48"	12	
48"-54"		

NOTE: Maximum of 20 turns (360°) of power adjustment Nut. Closer is shipped set at 7 turns from the factory

Main Arm Installation Instructions

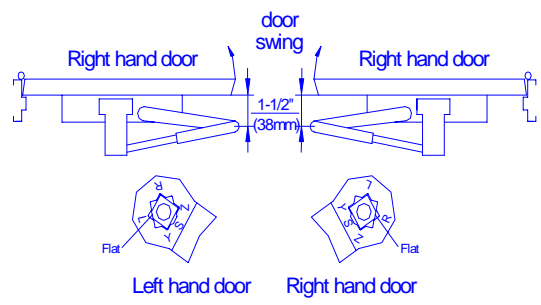

Use adjustable wrench to rotate spindle 45° counter-clockwise for right hand door or clockwise for left hand door. Place main arm on spindle so that the "R"(Right hand door) or "L"(Left hand door) lines up with the spindle flat. Secure main arm and spindle by tightening spindle bolt.

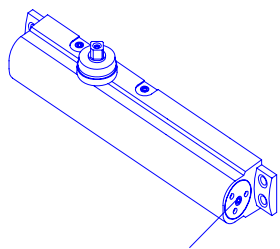

Power Adjustment Nut

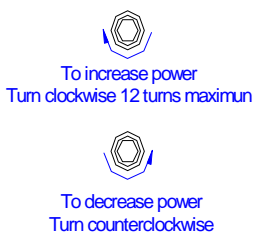

Unit adjustment

Closing speed controls (figure 1 and 2)

- Valve "S" controls sweep range
- Valve "L" controls latch range

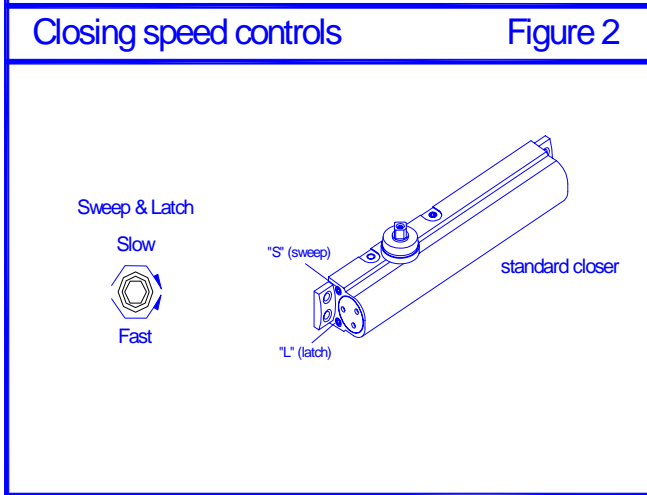
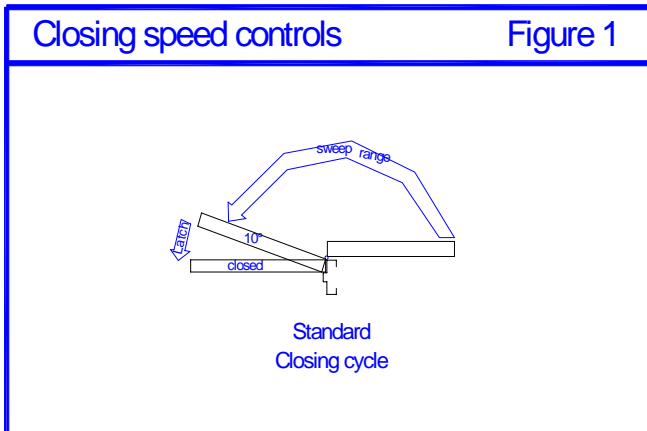

Opening door control (figure 4.)

- Backcheck ("B") Valve controls the hydraulic resistance to door opening. NEVER close this valve completely- it is not to provide a positive stop
- Backcheck position ("P") valve controls the door angle where backcheck cushioning starts. Valve normally closed.

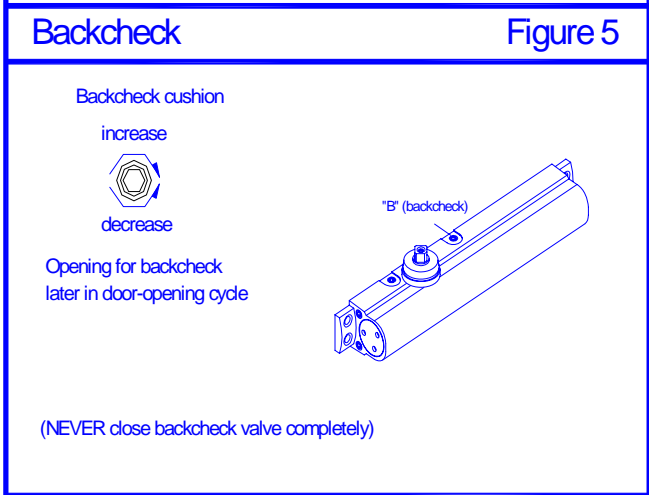
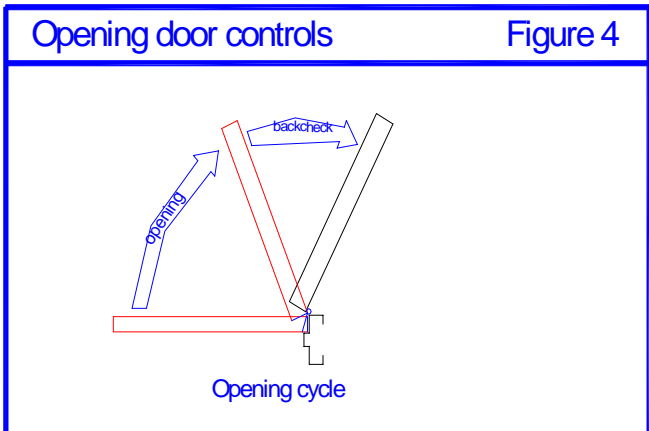

Closing power control (Figure 3)

- Adjust as required (see charts on pages 3, 4, & 5)

