

2000V Series EXIT DEVICE

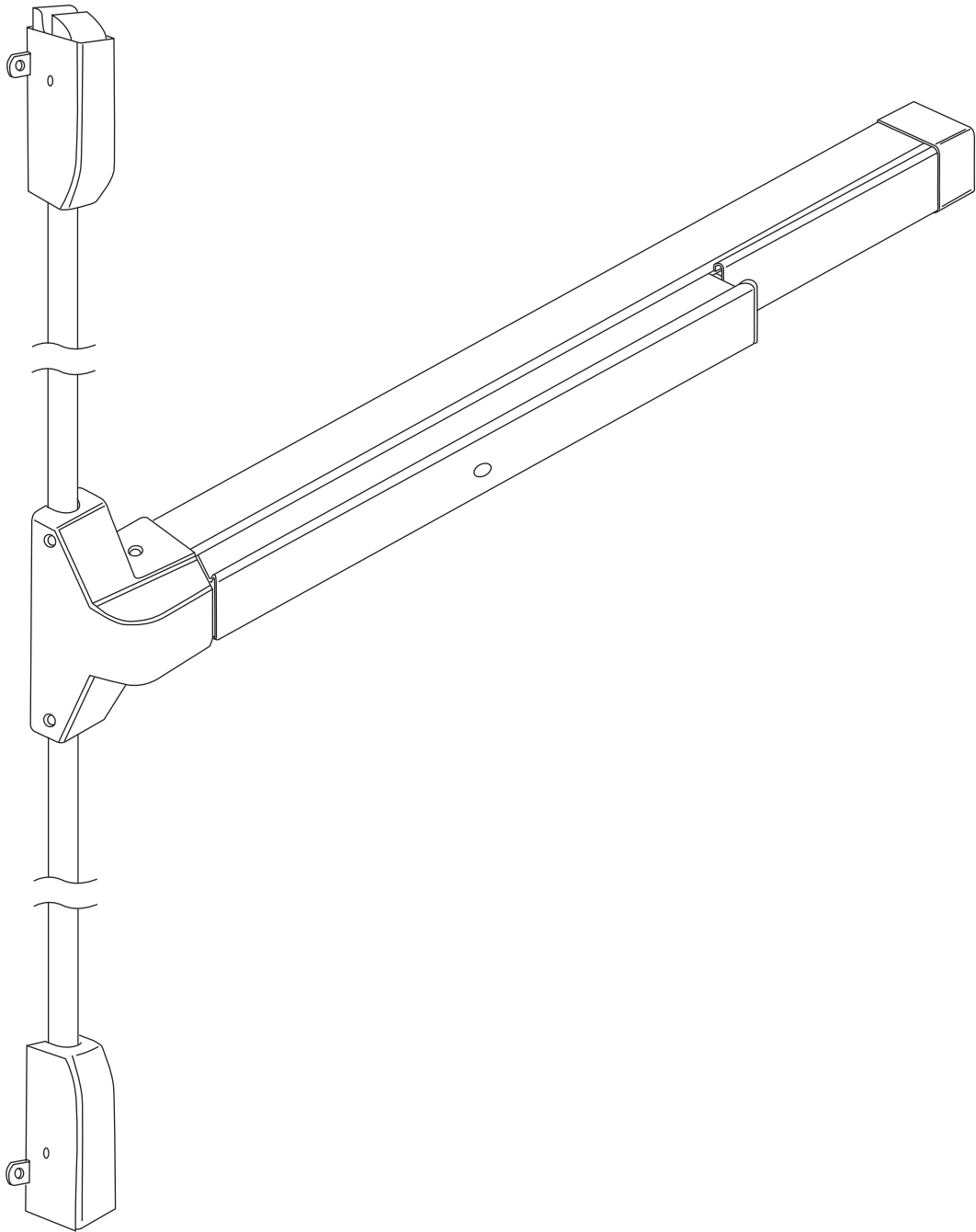

INSTALLATION INSTRUCTIONS

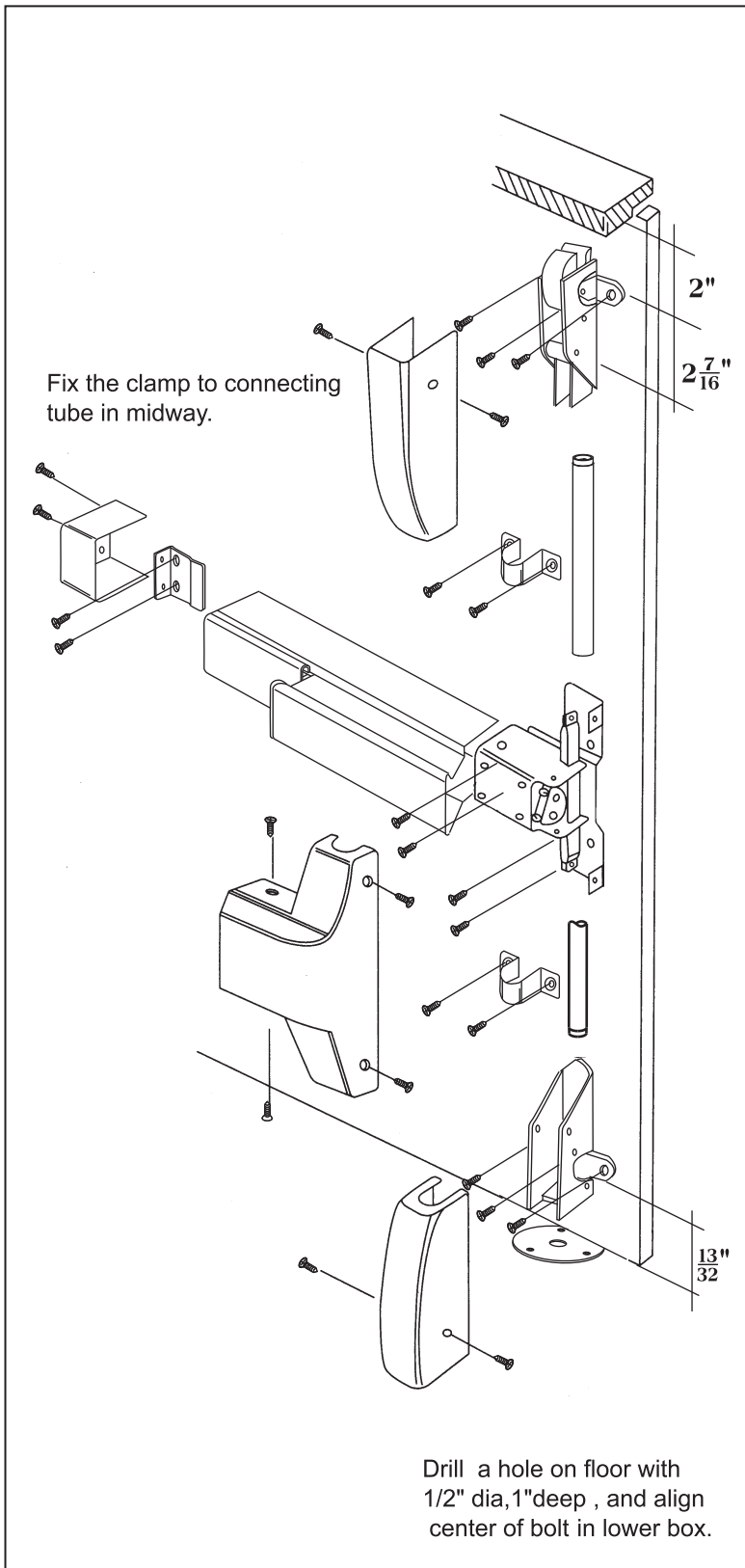

STEP 1: MARK CENTER LINE ON DOOR

Mark center line on inside of door. Establish the horizontal center line of the device by drawing a line across the door 40" above floor line.

STEP 2: MARK DOOR AND DRILL HOLES

1. Fold and apply template (A) to edge of door and mark door as indicated on template (A).
2. Drill holes Ax6 in accordance with the diameters as indicated on template (A).

STEP 3: INSTALL DEVICE BODY

1. Loosen screws and remove head cover and end cover.
2. Align holes of head with the holes on the door and tighten screws.

STEP 4: INSTALL TOP STRIKE

1. Align vertical center line of Top Strike and upper connecting tube as shown on template (B). Mark door as indicated on template (B).
2. Tighten screws to install Top Strike with proper adjustment

STEP 5: INSTALL TOP LATCH UNIT

1. Align vertical center line of top latch unit and upper connecting tube as shown on template (B). Mark door as indicated on template (B).

CAUTION: BE SURE THE DISTANCE FROM DOOR FRAME TO LINE

W MUST BE 2*

2. Tighten screws to install top latch unit.

STEP 6: DIRECTIONS FOR CHANGING HANDING OF DEVICE

Handing of device is preset at factory for RHR. To change handing of device, follow steps shown below.

1. Loosen screws 'A' and remove screw 'B' and spring 'C'.
2. Reverse the positions of screw 'B' and spring 'C' and then tighten screw
3. The device is now set for LHR.

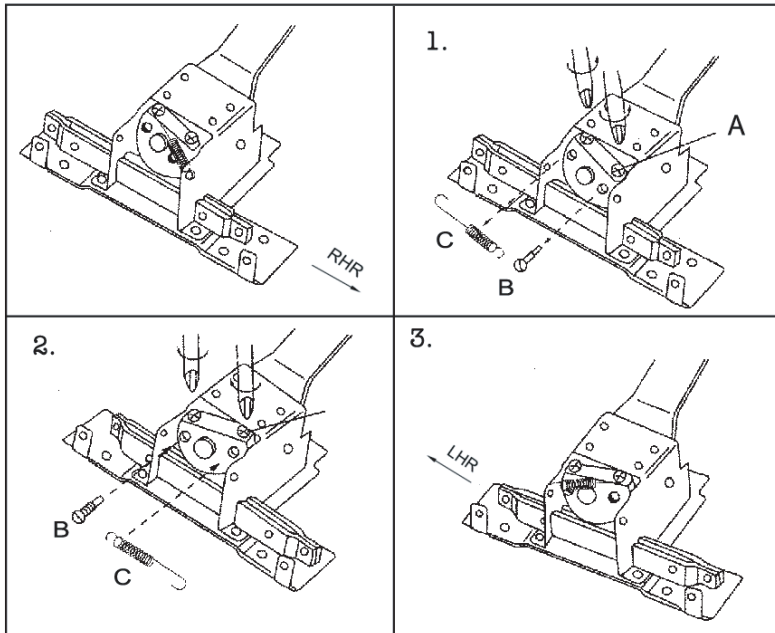

STEP 7: INSTALL BOTTOM LATCH UNIT

1. Align vertical center line of bottom latch unit and lower connecting tube as shown on template Mark door as indicated on template (B).

CAUTION: BE SURE THE DISTANCE FROM THE BOTTOM SIDE DOOR TO THE BOTTOM OF LATCH IS 13/32".

2. Tighten screws to install bottom latch unit.

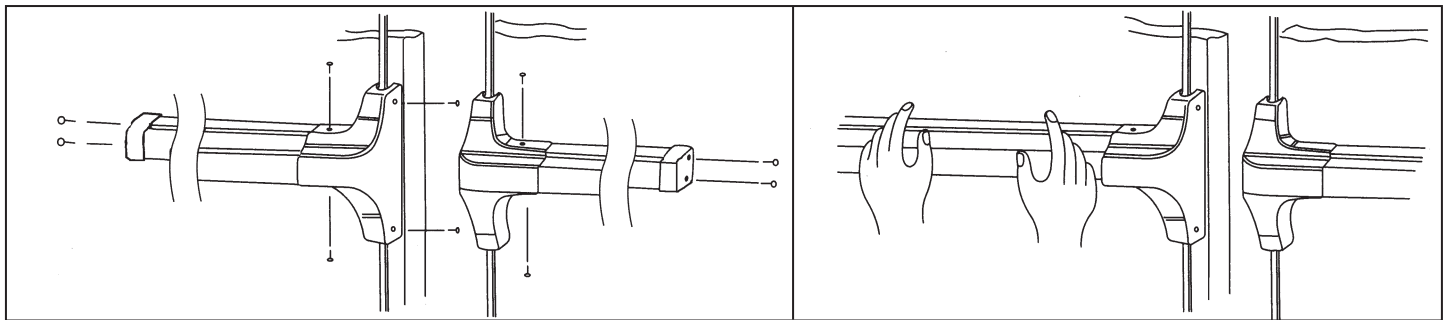

STEP 8: INSTALL AND ADJUST UPPER CONNECTING TUBE

1. Keep the end of the tube with the threaded insert upward to connect it with the threaded bolt in the top latch unit.
2. Connect the other end of the tube to the internal mechanism of the head assembly by inserting the connecting pin into the holes.
3. Turn and adjust upper connecting tube until top latch unit retracts properly and then insert the fixed pin.

STEP 9: INSTALL AND ADJUST LOWER CONNECTING TUBE

1. Keep the end of the tube with the threaded insert downward to connect it with the threaded bolt in the bottom latch unit.
2. Connect the other end of the tube to the internal mechanism of the head assembly by inserting the connecting pin into the holes.
3. Connect bolt lower box with lower connecting tube.
Then, depress push bar to check for proper retraction.
Do not let bolt in lower touch floor while depressing push bar.

- ## STEP 10:
1. Let the bolt in lower box touch floor and mark on floor.
 2. Drill a 1/2" dia, 1" deep hole and Strew Floor Strike to the floor.

STEP 11: TEST PUSH BAR AND DOGGING OPERATIONS:

1. The top latch unit should engage the Top Strike and the bottom latch unit should engage the floor Strike when the door is closed. If the door can be pushed open without depressing the push bar, the upper connecting tube has been over adjusted. Adjust it as needed.
2. The top and bottom latch units should disengage from the strike freely when the push bar is depressed or dogged down. If they do not disengage, adjust the upper connectors as needed and retest for proper operation.

STEP 12: INSTALL TWO ROD GUIDES:

1. Take the approximately middle of upper and lower connecting tube.
2. Tighten screws to install rod guide

PARTS IDENTIFICATION

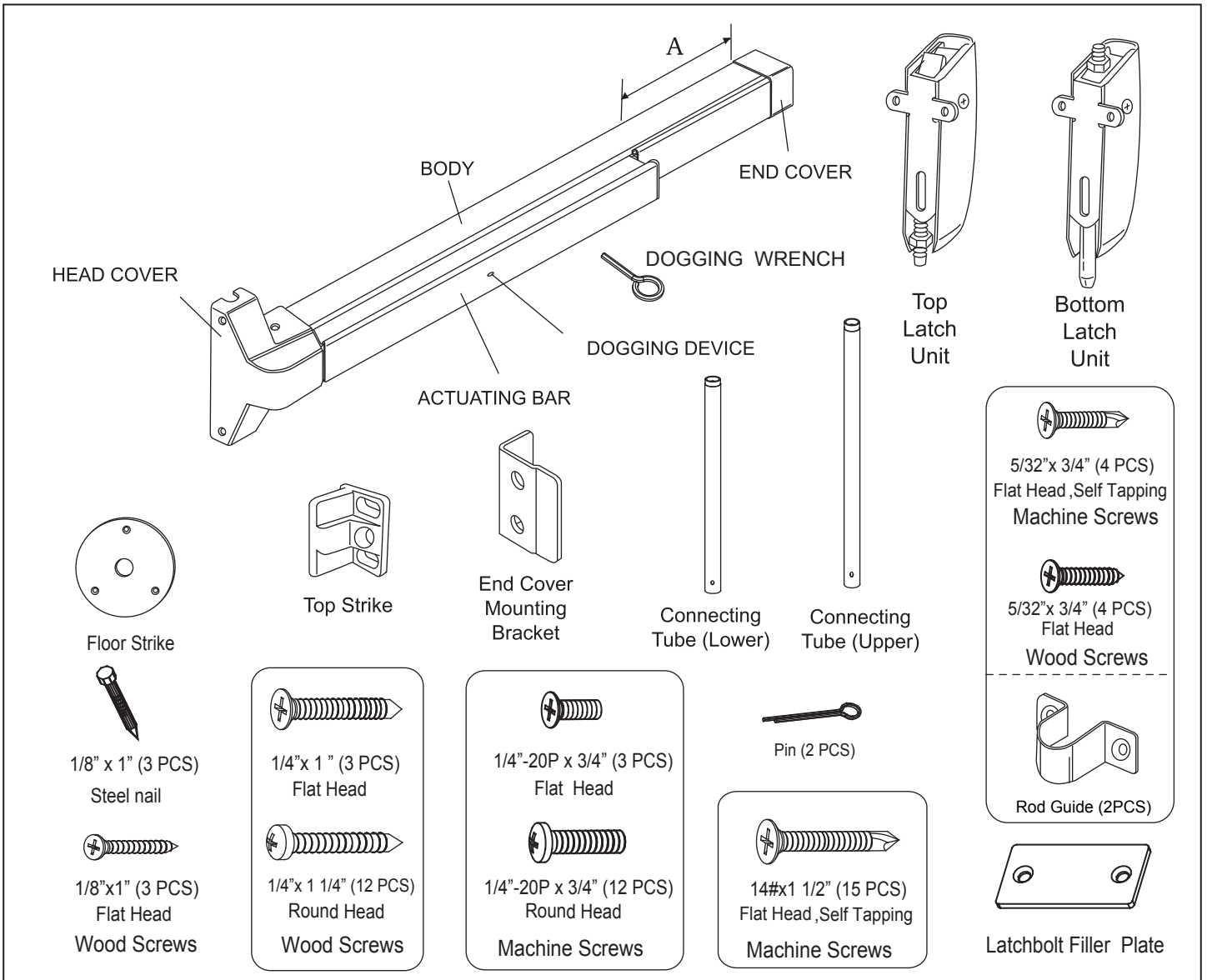

DOOR HANDING

Note: If door is LHR , please refer to step 6

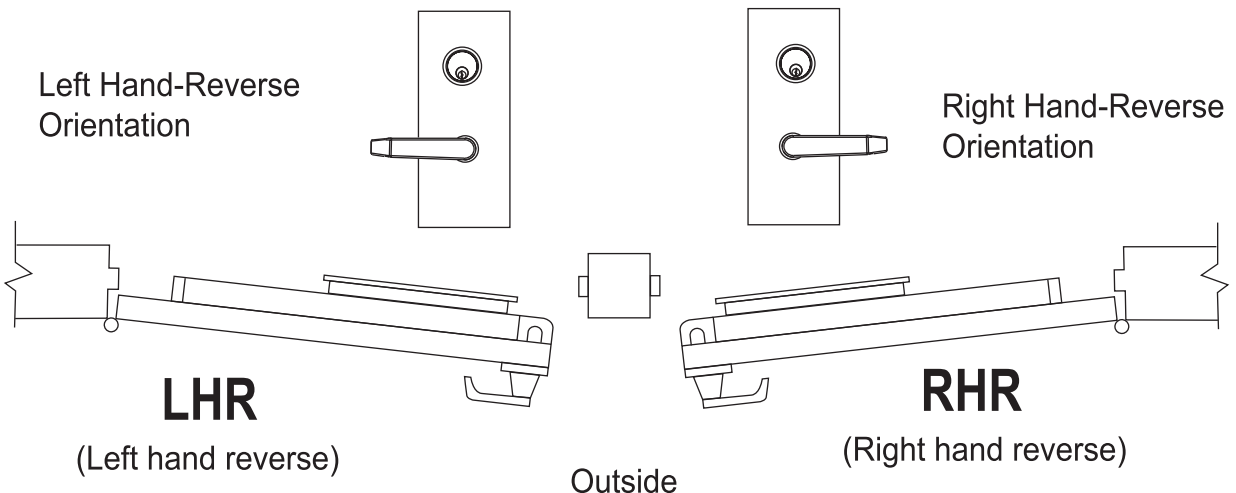

(A) For 2000V Series (UL Listed)-Drill & tap for (6) 1/4"-20P x 3/4" machine screws for Exit Device.

Drill (6) 7/32" Pilot Holes for Self Tapping machine screws or wood screws for Exit Device.

TEMPLATE (A)

(B) For F2000V (Fire Rated)-Drill 9/32" holes inside and 3/8" holes outside for the (6) thru bolts.

FOR RIGHT HAND DOOR INSTALLATION

FOR LEFT HAND DOOR INSTALLATION

1/4"-20P x 3/4" x 6
Round Head Screws

1/4"-20P x 3/4" x 6
Round Head Screws

CAUTION: If without key cylinder installation
do not drill this hole

CAUTION: If without key cylinder installation
do not drill this hole

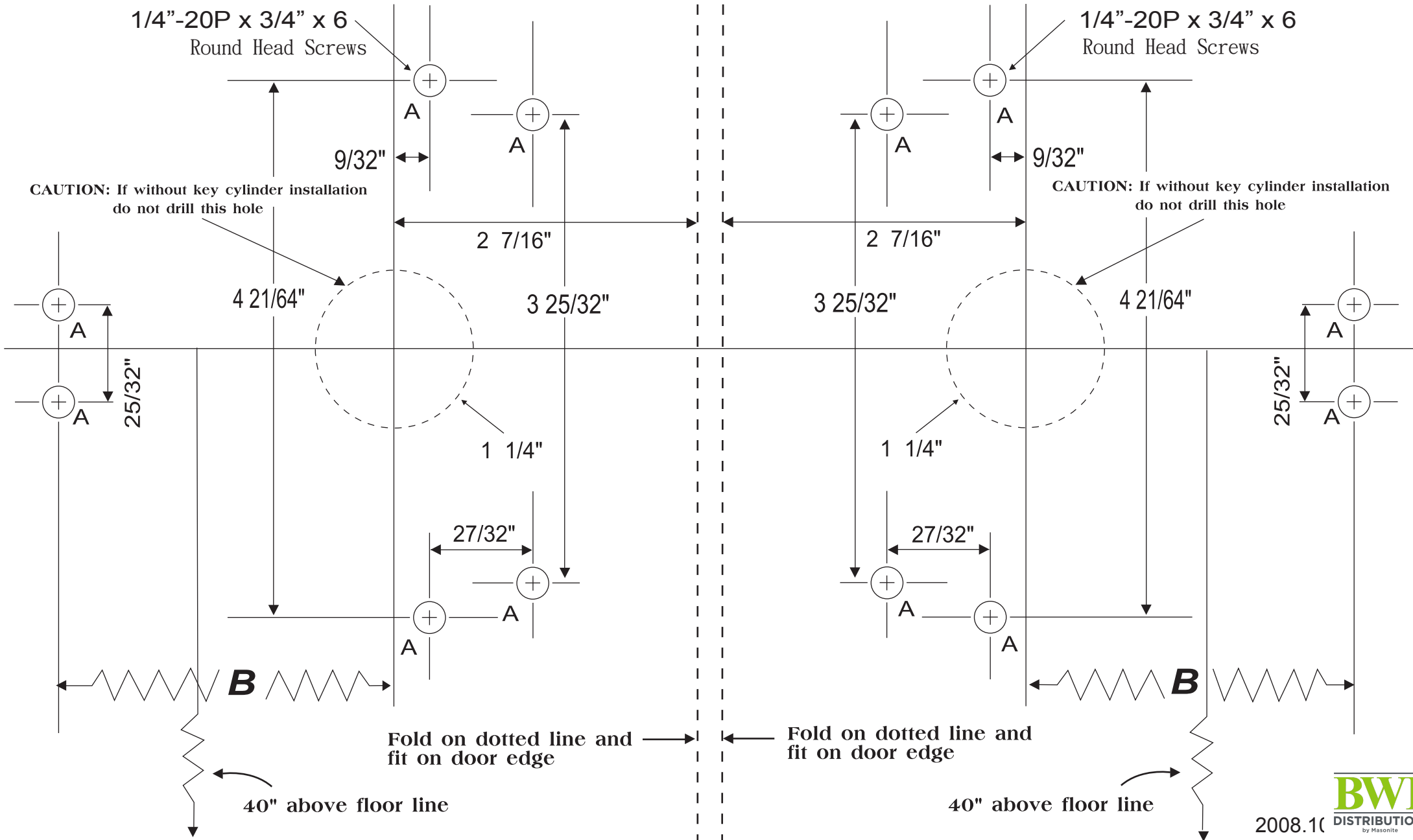

Fold on dotted line and
fit on door edge

Fold on dotted line and
fit on door edge

40" above floor line

40" above floor line

(A) For 2000V Series (UL Listed)-Drill & tap for (6) 1/4"-20P x 3/4" machine screws (4xD, 2xE) for Exit Device.

Drill (6) 7/32" Pilot Holes (4xD, 2xE) for Self Tapping machine screws or wood screws for Exit Device.

(B) For F2000V (Fire Rated)-Drill 9/32" holes (4xD, 2xE) inside and 3/8" holes (4xD, 2xE) outside for the (6) thru bolts.

← 1" → **TOP STRIKE**

TEMPLATE(B)

CAUTION :

BE SURE THE DISTANCE FROM DOOR FRAME TO LINE W MUST BE 2"

FOLD REVERSELY FOR TOP STRIKE INSTALLATION

G

G 1/4"-20P x 3/4" x 2

FLAT HEAD MACHINE SCREWS

D

D

1/4"-20P x 3/4" x 4
ROUND HEAD SCREWS

--- LINE W

FOLD ON DOTTED LINE AND FIT ON DOOR FRAME

F 1/4"-20P x 3/4" x 1

FLAT HEAD MACHINE SCREWS

CAUTION : DRILL "F" HOLE AFTER LATCH BOLT PROPERLY WORKS.

2 7/16"

1 39/64"

TOP LATCH UNIT

Note: When installing top latch unit:

1. Drill (1) E hole and install screw but do not tighten all the way.
2. Make sure distance from door frame to line W is 2".
3. Drill (2) D holes and install and tighten screws.
4. Tighten screw in hole E all the way.

E 1/4"-20P x 3/4" x 2
ROUND HEAD SCREWS

BOTTOM LATCH UNIT

CAUTION :

BE SURE THE DISTANCE FROM BOTTOM SIDE OF DOOR EDGE TO BOTTOM OF BOTTOM LATCH UNIT MUST BE 13/32"

2 7/16"

13/32"

29/32"

1 39/64"

D

D