

# TEMPLATE FOR INSTALLING PANIC EXIT DEVICE

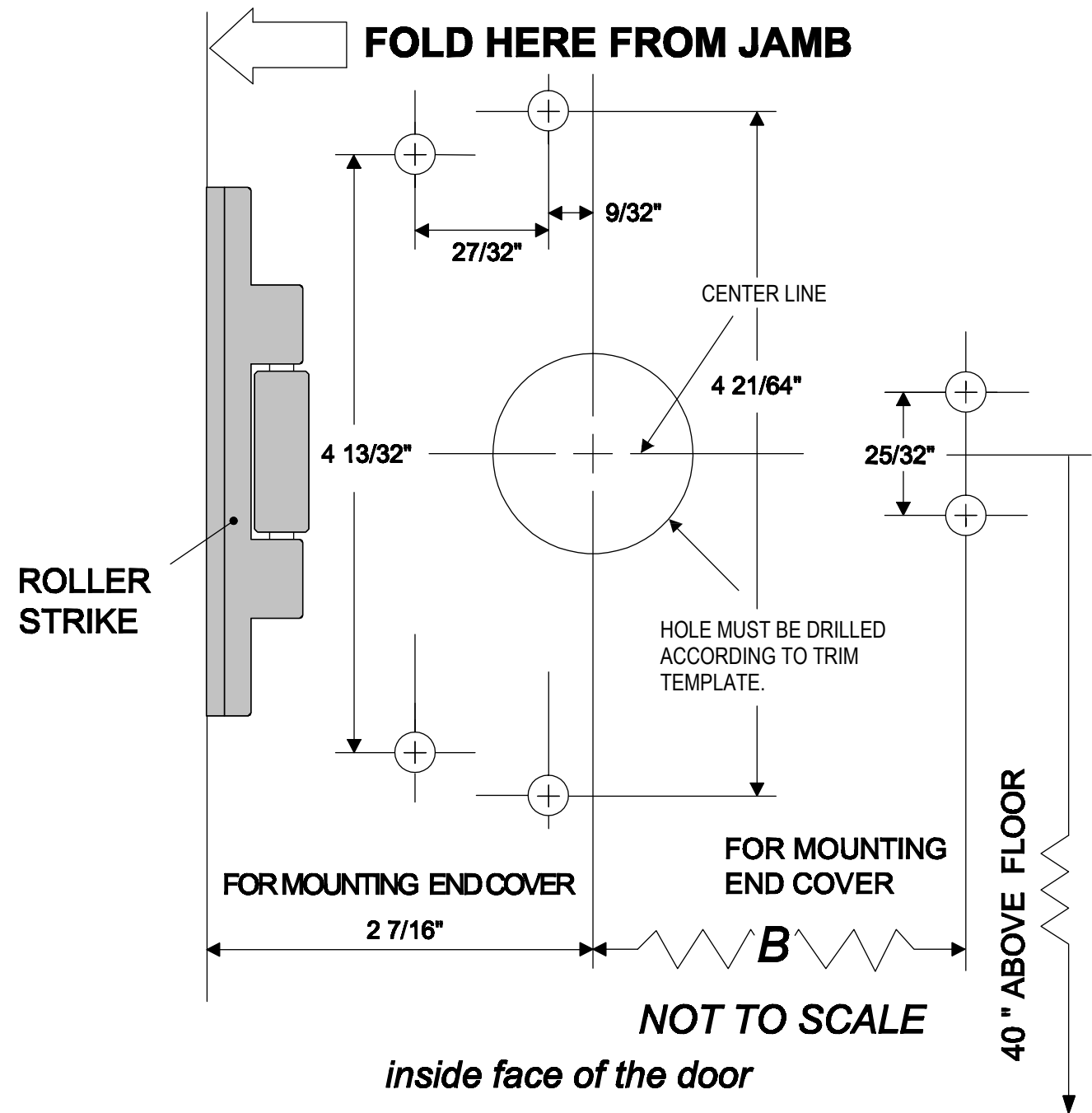
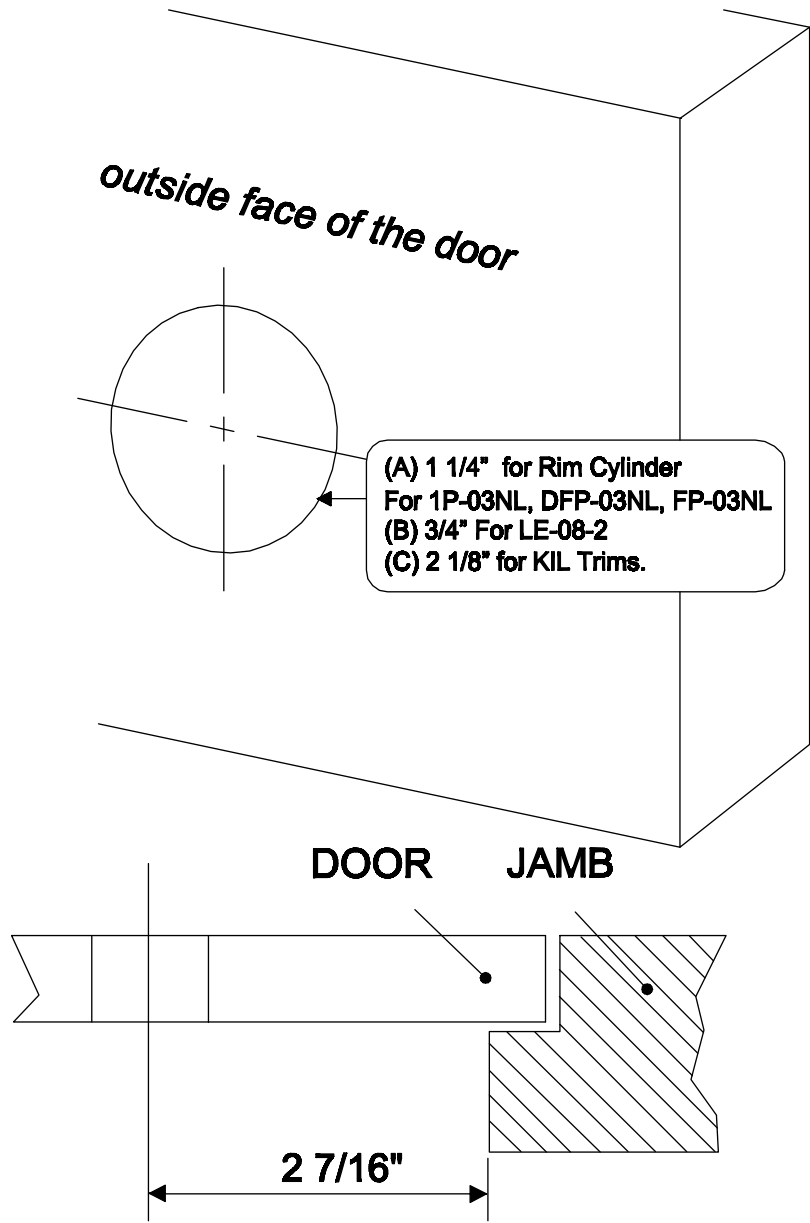

(A) For 2000R Series (UL Listed)-Drill & tap for (6) 1/4"x20 machine screws for Exit Device and Drill & tap for (3) 1/4"x20 machine screws for Roller Strike  
OPTIONAL for 2000R (UL Listed)

Drill (6) 7/32" Pilot Holes for Self Tapping machine screws or wood screws for Exit Device and  
Drill (3) 7/32" Pilot Holes for Self Tapping machine screws or wood screws for Roller Strike

(B) For F2000R (Fire Rated)-Drill 9/32" holes inside and 3/8" holes outside for the (6) thru bolts and drill & tap for (3) 1/4"x20 machine screws for Roller Strike.